

Product

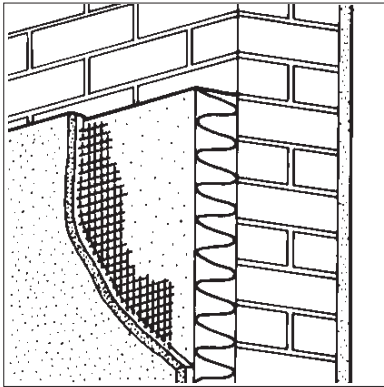

• THIS DETAIL SHEET RELATES TO THE WEBER.THERM XM (PHS) EXTERNAL WALL INSULATION SYSTEM, EMPLOYING PHENOLIC INSULATION BOARD, AND A GLASS-FIBRE REINFORCED UNDERCOAT WITH A DRY-DASH RENDER, OR TEXTURED FINISH.

• The system is applied to the outside of external walls of masonry, dense or no-fines concrete construction and is suitable for new or existing buildings.

• It is essential that the system is installed and maintained in accordance with the conditions set out in the Design Data and Installation parts of this Detail Sheet.

This Detail Sheet must be read in conjunction with the Front Sheets, which give general information relating to the product, the system's position regarding the Building Regulations and Conditions of Certification, respectively.

Technical Specification

1 Description

1.1 The weber.therm XM (PHS) External Wall Insulation System (see Figure 1) comprises:

- Phenolic insulation board — 1200 mm by 600 mm in a range of thicknesses between 20 mm and 70 mm in 10 mm increments, with a nominal density of 40 kgm^{-3} and a minimum compressive strength of 150 kNm^{-2} . Boards of 15 mm thickness are also available for use in window reveals
- weber.rend LAC — a factory batched, polymer-modified, basecoat mortar supplied as a powder, to which only water is added
- weber Fibreglass Meshcloth — a one-metre wide, woven glass-fibre reinforcing mesh with a polymer coating and a nominal weight of 160 gm^{-2}
- weber.rend PTC — a factory batched, pre-mixed, polymer-modified mortar of limestone sand, Portland cement, fibres and polymers. It is supplied as a powder to which only water is added
- weber Dry-Dash aggregate — natural coloured, sized up to 6 mm and available in a range of colours

Figure 1 weber.therm XM (PHS)
External Wall Insulation System

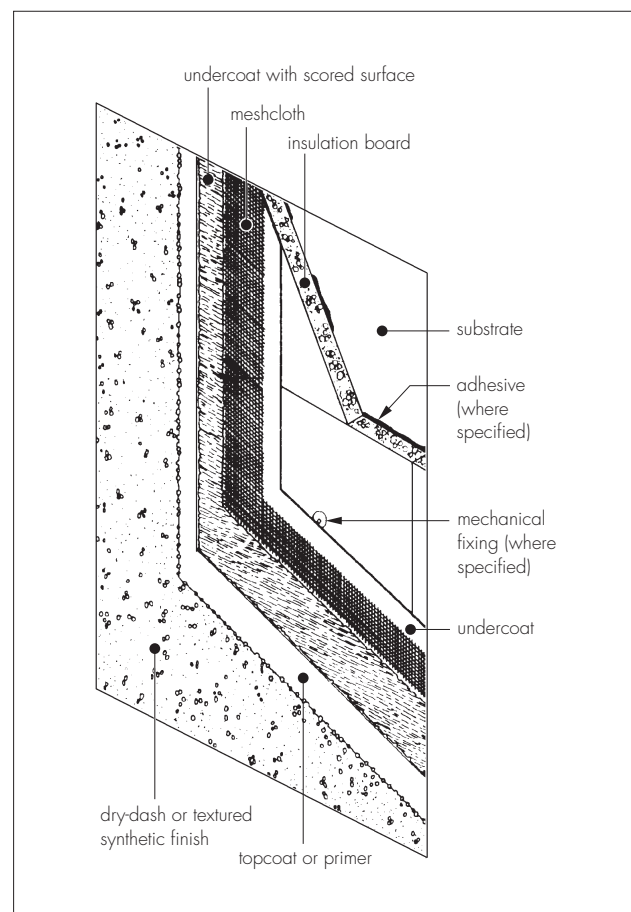

- weber PR310 — a styrene acrylic, resin-based emulsion containing fine fillers, pigment and coalescing agent used as a bonding aid and pre-coat to control suction
- weber.plast TF — an acrylic-bonded, textured plaster supplied in various grades as a paste containing aggregate (1.5 mm or 3 mm maximum grain size). The product is available in an extensive range of colours, details of which can be obtained from the Certificate holder
- weber.plast DF — a factory pre-mixed, resin-based composite containing natural white limestone aggregate (1 mm or 3 mm maximum grain size), limestone sand, whiting, fillers and pigments. It is available in a range of colours as a drag texture finish
- weber.sil TF — a silicone-bonded, textured plaster supplied as a paste in two grades containing aggregate (1.5 mm or 3 mm maximum grain size). The product is available in an extensive range of colours, details of which can be obtained from the Certificate holder
- Ancillary materials:
 - weber profiles — a range of standard profiles for such details as wall base, end stop, corner mesh and expansion joint, produced in two main material specifications; either stainless steel number 1.4301 to BS EN 10088-1 : 1995, or galvanized steel strip DX51D + Z275 N-A-U to BS EN 10327 : 2004 with or without a polyester powder paint finish to BS 6497 : 1984. Aluminium or rigid PVC profiles are also available. Profiles are provided to the specifier's requirements and approved by the Certificate holder
 - weber profile fixings — galvanized, plated or stainless steel screws or driven pins with plastic expansion sleeves. Alternatively, integral plastic finned nails with mushroom heads
 - sealant — silicone as approved by the Certificate holder
 - aluminium and rigid plastic beads
 - weber mechanical fixings — fixings are selected for use with no-fines concrete substrates and, where specified, from the following general types⁽¹⁾:
 - stainless steel fixing with central expansion pin (minimum pull-out 1000 N)
 - stainless steel tube fixing (minimum pull-out 600 N)
 - polypropylene finned fixing (minimum pull-out 500 N)
 - polypropylene ribbed fixing with central expansion pin (minimum pull-out 600 N)

– nylon fixing with metal central pin (minimum pull-out 1000 N).

(1) Details of approved fixings may be obtained from the BBA.

1.2 The insulation boards may be mechanically fixed to the substrate at the minimum frequency of five fixings per board. Alternatively, the boards may be bonded to the external faces of walls using an adhesive coat with two supplementary fixings evenly spaced horizontally along the centre of each board to secure the insulation while the adhesive mortar sets. For installation on no-fines concrete substrates, the insulation boards are secured in position with mechanical fixings.

1.3 The undercoat is applied in two layers, with the mesh in between, to give a finished undercoat thickness of approximately 6 mm. The undercoat is allowed to cure (ie dry and shrink), before applying one of the finishes (see Figure 2).

Figure 2 Typical section at base level

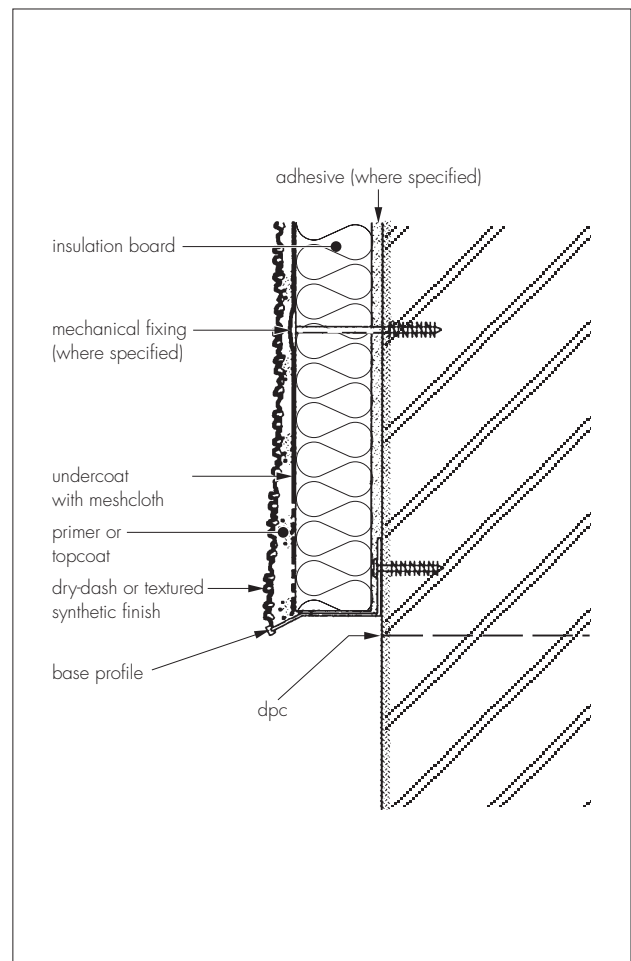

1.4 Where a dashed finish is required, weber.rend PTC is applied to a thickness of approximately 6 mm, and dry-dashed immediately. Where a textured acrylic or silicone finish is required, the primer is applied by brush to the undercoat. After a sufficient drying period the weber.plast TF and weber.plast DF, or weber.sil TF finish is trowel applied (see Figure 2).

Design Data

2 Thermal insulation

2.1 For the purpose of U value calculations to determine if the requirements of the Building (or other statutory) Regulations are met, the thermal conductivity⁽¹⁾ of the insulation board ($\lambda_{90/90}$ value) as stated by the insulation manufacturer may be taken as $0.022 \text{ Wm}^{-1}\text{K}^{-1}$.

(1) Not assessed by the BBA.



2.2 The requirement for limiting heat loss through the building fabric, including thermal bridging, will be satisfied if the U values of the building elements do not exceed the maximum values in the relevant Elemental Approach given in the national Building Regulations:

England and Wales

Approved Documents L1 and L2, Table 1

Scotland

Technical Standards J3.2, Table 1, and J8.3, Table

Northern Ireland

Technical Booklet F, Table 1.2 or 1.4.

2.3 Guidance is also given in these documents on selecting the thickness of insulation required to enable a wall to achieve the desired U value. Alternative approaches are also described which allow for some flexibility in design of U values for individual constructional elements.

2.4 Where the insulation has not been continued into window or door reveals due to a lack of clearance there will be a risk of cold bridging at these points. Where door and window frames are to be replaced it is recommended that their size be adjusted to permit the reveals to be insulated.

2.5 Depending on constructional details, cold bridging can also occur at the eaves and at ground-floor level, and care should be taken to minimise this, eg roof or loft insulation should continue over the wall head. Care should be taken to ensure that ventilation openings are not obstructed.

Installation

3 Procedure

General

3.1 Application is carried out in accordance with the current installation instructions of the Certificate holder.

3.2 Weather conditions should be monitored to ensure correct application and curing conditions. Application of the undercoat and finishes should not be carried out at temperatures

below 5°C or above 30°C , nor if exposure to frost is likely. The coating must be protected from rapid drying.

3.3 All rendering should be in accordance with the relevant recommendations of BS 5262 : 1991 and BS 8000-10 : 1995.

Positioning and securing insulation boards

3.4 The base profile is secured to the external wall above the damp-proof course using approved profile fixings at 700 mm maximum centres (see Figure 2).

3.5 The adhesive coat is prepared and mixed to a smooth, workable consistency and applied to the insulation boards. The adhesive is applied to the back of the insulation boards in four vertical strips 100 mm wide, 25–30 mm wide. The adhesive should cover at least 50% of the board (see Figure 3).

Figure 3 Typical insulation fixing pattern

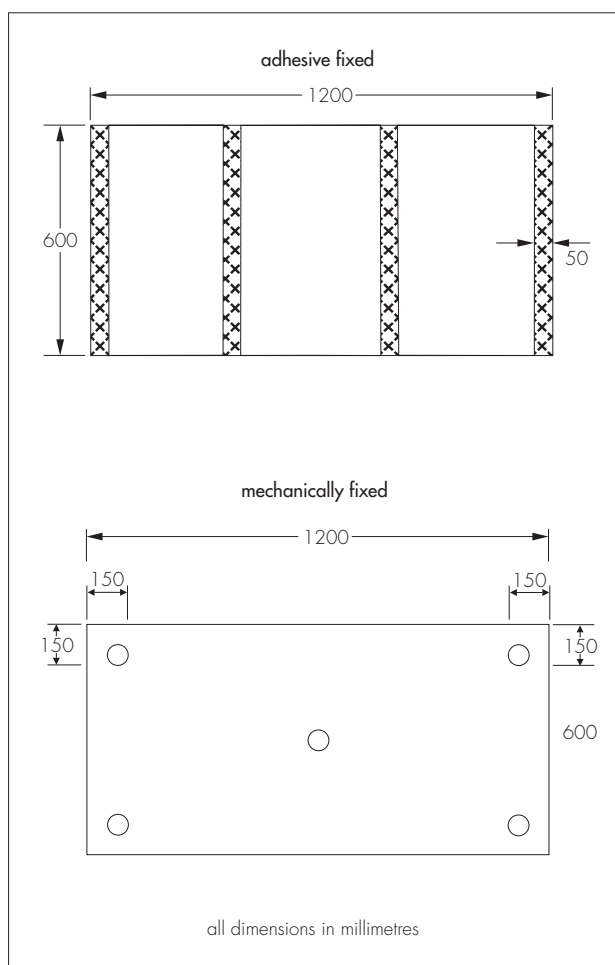

3.6 The first run of insulation boards is positioned on the base profile. The boards are pressed firmly against the wall.

3.7 Insulation boards may be fixed temporarily while the adhesive sets by using two supplementary fixings, evenly spaced horizontally on the centre line of each board. Subsequent rows of boards are positioned so that the vertical board joints are staggered and overlapped at the building corners (see Figure 4).

Figure 4 Arrangement of insulation boards

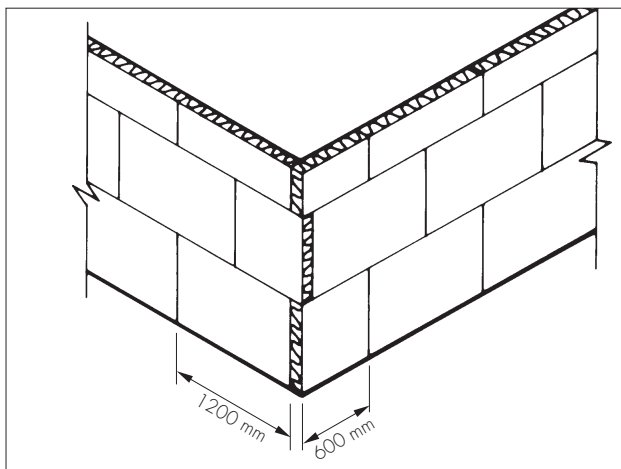

3.8 For no-fines concrete substrates and mechanically-fixed systems (see Figure 3), holes are drilled into the substrate through the insulation board and mechanical fixings inserted and tapped firmly home to secure the boards at the specified minimum rate of five fixings per board or seven fixings per m^2 (see the *Strength and stability* section in the Front Sheets).

3.9 Care must be taken to ensure that all board edges are butted tightly together, and surface alignment should be checked as work proceeds. Surface irregularities are taken up by applying the adhesive coat to the back of the insulation boards.

3.10 To fit around details such as doors and windows, insulation boards may be cut with a sharp knife or a fine-toothed saw. If required, purpose-made window-sills are fitted at this stage. They are designed to prevent water ingress and incorporate drips to shed water clear of the system.

3.11 Installation continues until the whole wall is completely covered including, where appropriate, the building soffits.

Movement joints

3.12 Movement joints in the substrate must be continued through the system by cutting through the insulation boards to coincide with the building's movement joint. The weber expansion joint metal profile is fixed to the insulation board surface with adhesive mortar, prior to application of the reinforced undercoat (see Figure 5).

Figure 5 Vertical movement joint

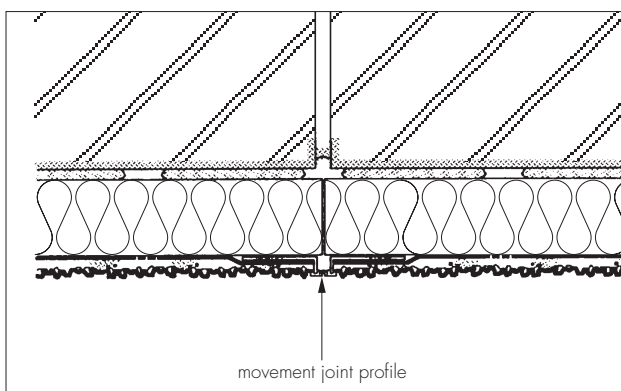

3.13 The extent of a rendered area should take account of the shape of the work. Where necessary, render movement joints are formed as above.

Reinforcing

3.14 The undercoat is prepared and trowel applied to the surface of the dry insulation to an approximate thickness of 2 mm to 3 mm. The mesh is bedded into the undercoat with 100 mm laps at joints and a further coat is applied. The overall undercoat thickness is approximately 6 mm. Additional pieces of reinforcing mesh are used diagonally at the corners of openings, as shown in Figure 6.

Figure 6 Additional reinforcement at openings

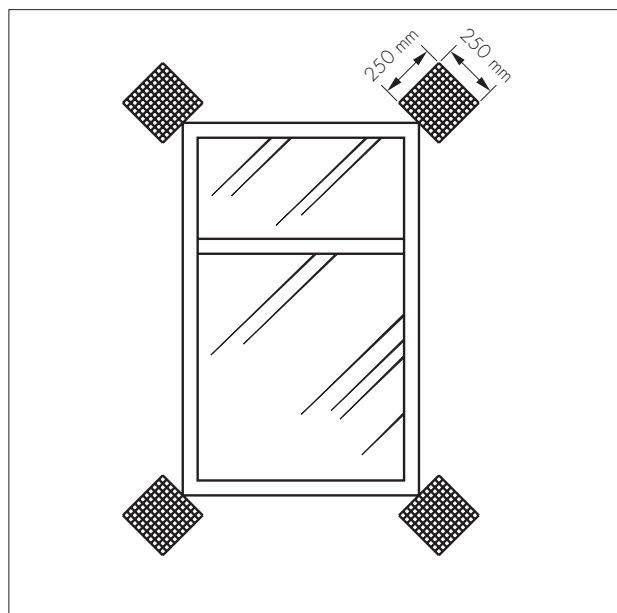

3.15 Care is taken to butt the undercoat under details such as window-sills. The surface of the undercoat is trowelled smooth and depending on the finish, lightly sponged, or scored, combed to provide a good even surface for the finish.

Beads

3.16 Expansion beads are fixed vertically as day joints, ideally over existing joints.

3.17 Stop beads are positioned vertically, eg at party-wall positions where the adjoining house does not require treatment.

3.18 Where required, angle beads are fixed to all building corners and to door and window heads and jambs.

Render finishing

3.19 The undercoat must be left to cure for at least two to three days depending on weather conditions before application of the finish.

3.20 Where required, prior to the render coat, a bead of clear silicone sealant is gun applied at window and door frames, overhanging eaves, gas and electric meter boxes, wall vents or where the render abuts any other building material or surface.

3.21 The finish coat can either be a polymer-modified cementitious top coat with a dry-dash finish or synthetic coat, or a cement-free synthetic coat applied direct to the primed undercoat.

3.22 Where a dry-dash finish is required, the weber.rend PTC is prepared and mixed to a smooth, workable consistency.

3.23 One coat is trowel applied to a thickness of 6 mm. While the render is still soft the dry-dash is applied with a dashing trowel. Narrow widths of weber.rend PTC around window and door openings and in reveals, may be smooth float finished and painted with weber masonry paint. On completion, the surface should be checked to ensure an even coverage has been achieved. Where necessary, the aggregate should be lightly tamped to ensure that a good bond is achieved.

3.24 Where a weber.plast TF and weber.plast DF or weber.sil TF finish is required, the primer is brush applied and allowed to dry. The finishes should be mixed thoroughly before application over the undercoat. The chosen finish is applied with a steel trowel to a uniform thickness, depending on grain size and immediately worked with a thin, plastic or wooden float to produce the desired texture (see section 1).

3.25 To prevent the finish from drying too rapidly it should not be applied in direct sunlight. The finished render surface should be protected from rain and frost until the material is dry and hard, approximately 24 hours under favourable conditions; in winter, drying may take at least 48 hours. Continuous surfaces must be completed without a break.

3.26 At the tops of walls the system should be protected by an adequate overhang or by an adequately sealed, purpose-made flashing (see Figure 7).

Figure 7 Eaves detail — pitched roof

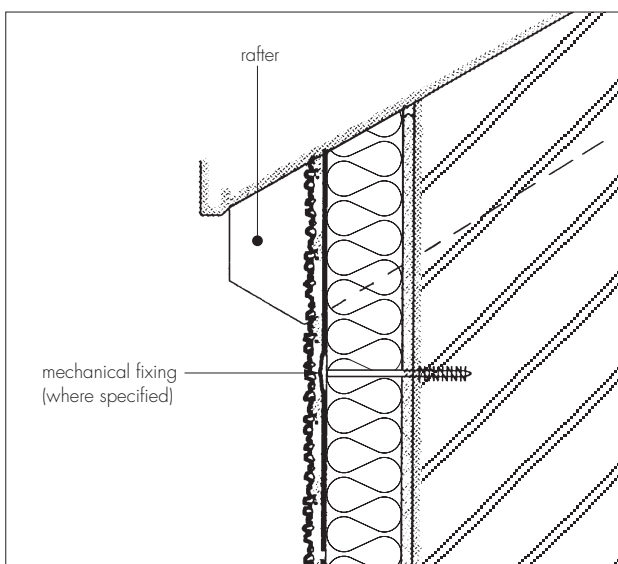

3.27 Care should be taken in the detailing of the system around openings and projections (see Figure 8).

3.28 On completion of the installation, external fittings, eg rainwater goods, are re-fixed through the system into the substrate.

Figure 8 Window details

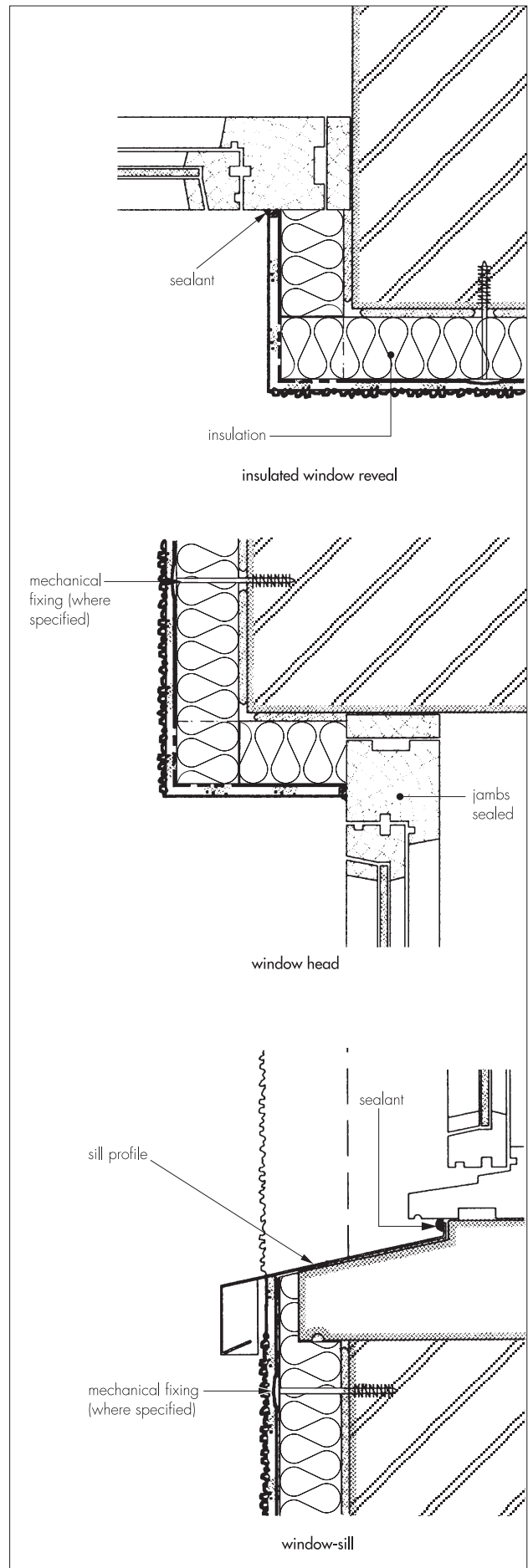

Technical Investigations

The following is a summary of the technical investigations carried out on the weber.therm XM (PHS) External Wall Insulation System.

4 Tests

4.1 Tests were carried out in accordance with MOAT No 22 : 1988 to determine:

- component characterisation
- resistance to freeze/thaw
- heat/spray cycling
- impact resistance.

4.2 An examination was made of data relating to:

- water vapour permeability
- fire propagation tests to BS 476-6 : 1989
- surface spread of flame tests to BS 476-7 : 1997
- pull-out strength of fixings
- durability of finish coatings.

5 Investigations

5.1 The manufacturing process, the methods adopted for quality control of manufactured and bought-in components, and details of the quality and composition of the materials used, were examined.

5.2 An assessment of the risk of interstitial condensation was undertaken.

5.3 The practicability of installation and the effectiveness of detailing techniques were examined.

Bibliography

BS 476-6 : 1989 *Fire tests on building materials and structures — Method of test for fire propagation for products*

BS 476-7 : 1997 *Fire tests on building materials and structures — Method of test to determine the classification of the surface spread of flame of products*

BS 5262 : 1991 *Code of practice for external renderings*

BS 6497 : 1984 *Specification for powder organic coatings for application and stoving to hot-dip galvanized hot-rolled steel sections and preformed steel sheet for windows and associated external architectural purposes, and for the finish on galvanized steel sections and preformed sheet coated with powder organic coatings*

BS 8000-10 : 1995 *Workmanship on building sites — Code of practice for plastering and rendering*

BS EN 10088-1 : 1995 *Stainless steels — List of stainless steels*

BS EN 10327 : 2004 *Continuously hot-dip coated strip and sheet of low carbon steels for cold forming — Technical delivery conditions*

MOAT No 22 : 1988 *UEAtc Directives for the Assessment of External Insulation Systems for Walls (Expanded Polystyrene Insulation Faced with a Thin Rendering)*



On behalf of the British Board of Agrément

Date of Third issue: 13th January 2005

Chief Executive

**Original Detail Sheet issued on 17th December 1998. This amended version includes a change of Certificate holder's name, and new component names.*

Blank page

British Board of Agrément

P O Box No 195, Bucknalls Lane
Garston, Watford, Herts WD25 9BA
Fax: 01923 665301

©2005

e-mail: mail@bba.star.co.uk
website: www.bbacerts.co.uk



For technical or additional information,
contact the Certificate holder (see
front page).
For information about the Agrément
Certificate, including validity and
scope, tel: Hotline 01923 665400,
or check the BBA website.