

## Product

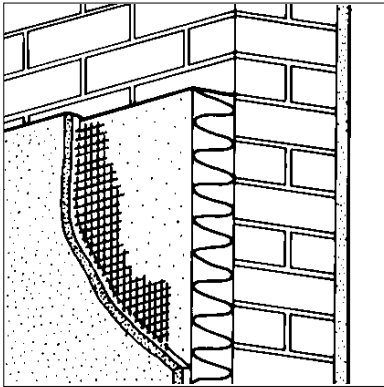

• THIS DETAIL SHEET RELATES TO THE WEBER.THERM XL (EPS) EXTERNAL WALL INSULATION SYSTEM, A SYSTEM EMPLOYING EXPANDED POLYSTYRENE INSULATION BOARD AND A METAL REINFORCED UNDERCOAT WITH A DRY-DASH RENDER OR TEXTURED FINISH.

• The system is applied to the outside of external walls of masonry, dense or no-fines concrete construction and is suitable for new or existing buildings.

• It is essential that the system is installed and maintained in accordance with the conditions set out in the Design Data and Installation parts of this Detail Sheet.

*This Detail Sheet must be read in conjunction with the Front Sheets, which give general information relating to the product, the system's position regarding the Building Regulations and Conditions of Certification, respectively.*

## Technical Specification

### 1 Description

1.1 The weber.therm XL (EPS) External Wall Insulation System (see Figure 1) comprises:

- weber coated EPS Insulation Board — 1220 mm by 610<sup>(1)</sup> mm in a range of thicknesses between 30 mm and 140 mm in 10 mm increments, with a nominal density of 15 kgm<sup>-3</sup> and a minimum compressive strength of 70 kNm<sup>-2</sup>. Boards are manufactured to comply with the requirements of EPS 70 Class E (flame retardant) material to BS EN 13163 : 2001. Each board is factory coated on one face with a polymer cement stipple coat of polymer mortar, a mixture of limestone sand, ordinary Portland cement and High Adhesion Mortar Additive
- (1) Special sizes of board can be supplied to meet the requirements of individual sites.
- weber.rend PUC Mortar (10 mm to 12 mm) — a factory batched, polymer-modified, basecoat mortar of ordinary Portland cement, limestone sand, lime, dry polymer and waterproofer, to which only water is added
- weber.rend TUC Mortar (10 mm to 12 mm) — a factory batched, pre-mixed base/undercoat mortar of sand, lime, cement and waterproofer, supplied as a powder, to which water only is added
- weber expanded metal lathing — 2440 mm by 1220 mm sheet, manufactured from expanded metal to form a diamond mesh pattern of 50 mm by 20 mm with 1.9 mm strands 0.56 mm thick. The metal lathing is available in the following materials:
  - galvanized (uncoated) mild steel strip BS EN 10327 : 2004 (Fe PO2 G Z 450 NA-U)
  - ferritic stainless steel grade 430S to BS EN 10051 : 1992 and BS EN 10259 : 1997; nominal weight 0.8 kgm<sup>-2</sup>
  - austenitic stainless steel grade 304S to BS EN 10051 : 1992 and BS EN 10259 : 1997; nominal weight 0.8 kgm<sup>-2</sup>.

Figure 1 weber.therm XL (EPS) External Wall Insulation System

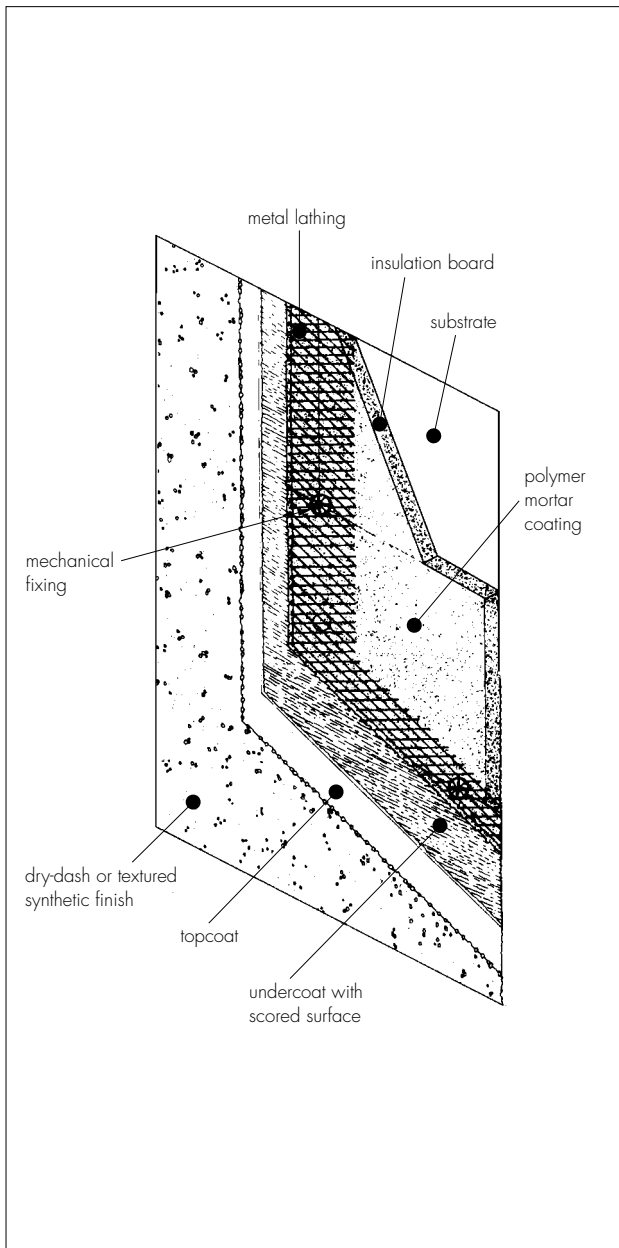

- weber.rend PTC (6 mm to 8 mm) — a factory batched, pre-mixed, polymer-modified topcoat mortar render of limestone sand, Portland cement, fibres and polymers. It is supplied as a powder to which only water is added
- weber.rend TTC render (6 mm to 8 mm) — a factory batched, pre-mixed mortar of limestone sand, cement and waterproofer, supplied as a powder to which water only is added; and
- weber.plast P — an acrylic-based paint with limestone sand and other additives — for a smooth float finish
- weber Dry-Dash aggregate — natural coloured, sized 6 mm to 9 mm and available in a range of colours, or
- weber.rend TTS Scratch or Float — a factory batched, pre-mixed mortar of limestone sand, cement, lime and waterproofer, supplied as a powder to which water only is added.

## 1.2 Synthetic render finishes include the following:

- weber PR310 — a styrene acrylic, resin-based emulsion containing fine fillers, pigment and coalescing agent used as a bonding aid and pre-coat to control suction
- weber.plast TF — an acrylic-bonded, textured plaster supplied in various grades as a paste containing aggregate (1.5 mm or 3 mm maximum grain size). The product is available in an extensive range of colours, details of which can be obtained from the Certificate holder
- weber.plast DF — a factory pre-mixed, resin-based composite containing natural white limestone aggregate (1 mm or 3 mm maximum grain size), limestone sand, whiting, fillers and pigments. It is available in a range of colours as a drag texture finish
- weber.sil TF — a silicone-bonded, textured plaster supplied as a paste in two grades containing aggregate (1.5 mm or 3 mm maximum grain size). The product is available in an extensive range of colours, details of which can be obtained from the Certificate holder
- Ancillary materials:
  - weber profiles — a range of standard profiles for such details as wall base, end stop and expansion joint, produced in two main material specifications; either stainless steel number 1.4301 to BS EN 10088-1 : 1995, or galvanized steel strip DX51D + Z275 N-A-U to BS EN 10327 : 2004. Profiles (beads) are provided to the specifier's requirements and approved by the Certificate holder
  - weber profile fixings — galvanized, plated or stainless steel screws or driven pins with plastic expansion sleeves. Alternatively, integral plastic finned nails with mushroom heads
  - sealant — silicone as approved by the Certificate holder
  - weber mechanical fixings — fixings are selected for use with no-fines concrete substrates and, where specified, from the following general types<sup>(1)</sup>:
    - stainless steel fixing with central expansion pin (minimum pull-out 1000 N)
    - stainless steel tube fixing (minimum pull-out 600 N)
    - polypropylene finned fixing (minimum pull-out 500 N)
    - polypropylene ribbed fixing with central expansion pin (minimum pull-out 600 N)

(1) Details of approved fixings may be obtained from the BBA.

1.3 weber.therm XL insulation boards are secured in position to the external faces of walls using mechanical fixings (see section 3.14).

1.4 The undercoat is applied over the lath to give a finished undercoat thickness of approximately 10 mm to 12 mm. The undercoat is allowed to cure (ie dry and shrink), before applying one of the finishes (see Figure 2).

Figure 2 Typical section at base level

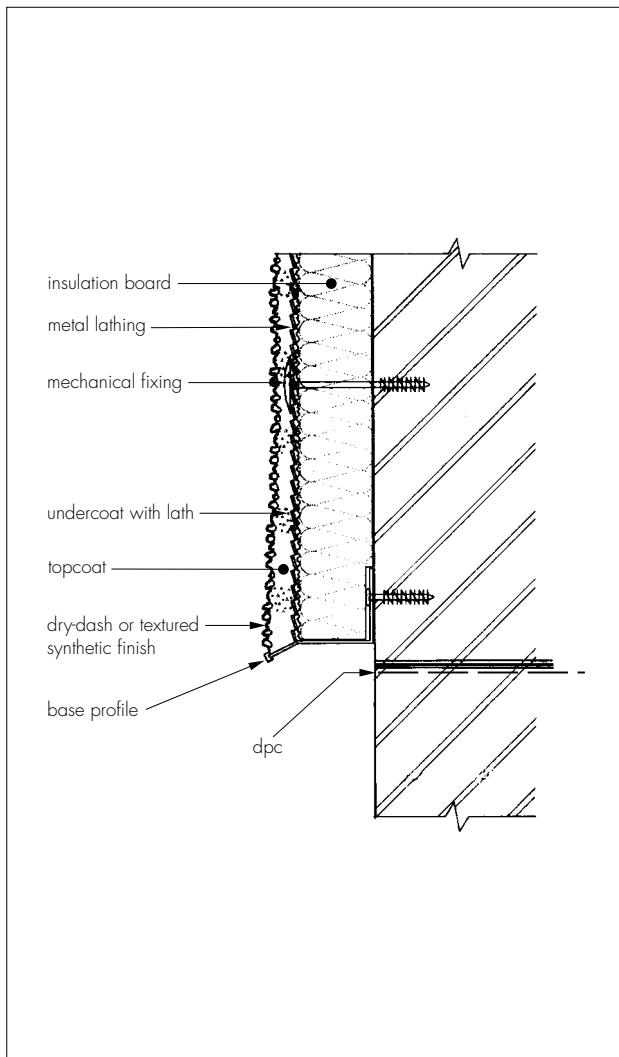

1.5 Where a dashed finish is required, weber.rend PTC/TTC is applied to a thickness of approximately 6 mm, and dry-dashed immediately. Where a textured acrylic or silicone finish is required, the primer is applied by spray, brush or roller to the topcoat. After a sufficient drying period the weber.plast TF and weber.plast DF, or weber.sil TF is trowel applied (see Figure 2).

## Design Data

### 2 Thermal insulation

2.1 For the purpose of U value calculations to determine if the requirements of the Building (or other statutory) Regulations are met, the thermal conductivity<sup>(1)</sup> ( $\lambda_{90/90}$  value) of the insulation board as stated by the insulation manufacturers, may be taken as  $0.038 \text{ Wm}^{-1}\text{K}^{-1}$ .

(1) Not assessed by the BBA.

2.2 The requirement for limiting heat loss through the building fabric, including thermal bridging, will be satisfied if the U values of the building elements do not exceed the maximum values in the relevant Elemental Approach given in the national Building Regulations:

#### England and Wales

Approved Documents L1 and L2, Table 1

#### Scotland

Mandatory Standard 6.2

#### Northern Ireland

Technical Booklet F, Table 1.2 or 1.4.

2.3 Guidance is also given in these documents on selecting the thickness of insulation required to enable a wall to achieve the desired U value. Alternative approaches are also described which allow for some flexibility in design of U values for individual constructional elements.

2.4 Where the insulation has not been continued into window or door reveals due to a lack of clearance there will be a risk of cold bridging at these points. Where door and window frames are to be replaced it is recommended that their size be adjusted to permit the reveals to be insulated.

2.5 Depending on constructional details, cold bridging can also occur at the eaves and at ground-floor level, and care should be taken to minimise this, eg roof or loft insulation should continue over the wall head. Care should be taken to ensure that ventilation openings are not obstructed.

## Installation

### 3 Procedure

#### General

3.1 Application is carried out in accordance with the current installation instructions of the Certificate holder.

3.2 Weather conditions should be monitored to ensure correct application and curing conditions. Application of the undercoat and finishes should not be carried out at temperatures below  $5^{\circ}\text{C}$  or above  $30^{\circ}\text{C}$ , nor if exposure to frost or wet conditions are likely. The coating must be protected from rapid drying.

3.3 All rendering should be in accordance with the relevant recommendations of BS 5262 : 1991 and BS 8000-10 : 1995.

#### Positioning and securing insulation boards

3.4 The base profile is secured to the external wall above the damp-proof course, using approved profile fixings at 700 mm maximum centres (see Figure 2).

3.5 The first run of insulation boards is positioned on the base profile.

3.6 weber insulation boards are fixed initially to the external surfaces of walls, with the polymer mortar coated surface facing outwards, using one centrally-placed mechanical fixing. Subsequent rows of boards are positioned so that the vertical board joints are staggered and overlapped at the building corners (see Figure 3).

Figure 3 Arrangement of insulation boards

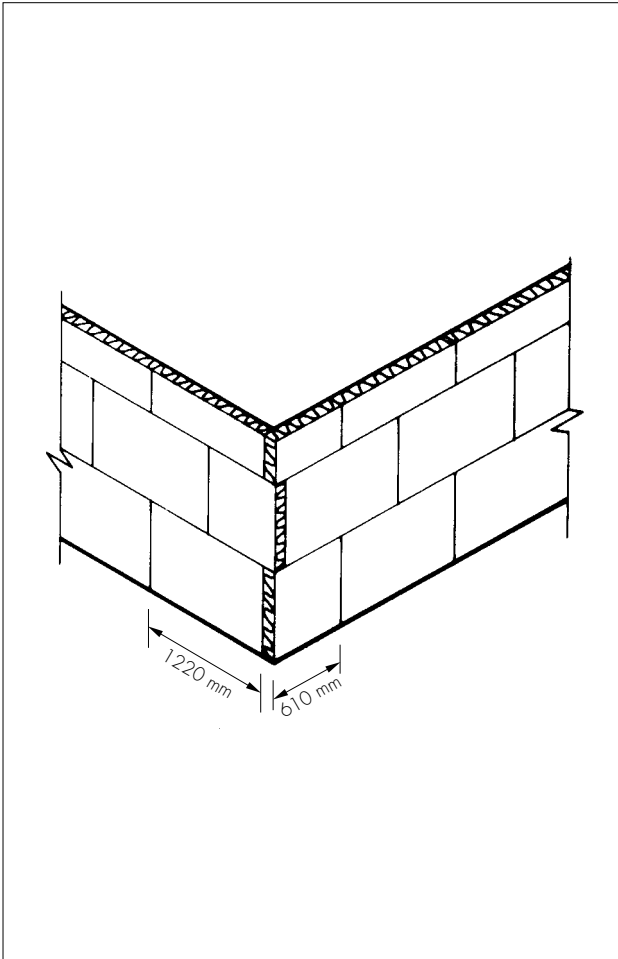

3.7 Care must be taken to ensure that all board edges are butted tightly together, and surface alignment should be checked as work proceeds.

3.8 To fit around details such as doors and windows, insulation boards may be cut with a sharp knife or a fine-toothed saw. If required, purpose-made window-sills are fitted at this stage. They are designed to prevent water ingress and incorporate drips to shed water clear of the system.

3.9 Installation continues until the whole wall is completely covered including, where appropriate, the building soffits.

3.10 Using a paddle mixer, mix weber Stipple Mortar to a smooth, workable consistency and apply to any exposed insulation board edges to provide a good key and stand-off for the subsequent basecoat.

3.11 Movement joints in the substrate must be continued through the system by cutting through the insulation boards to coincide with the building's movement joint. The weber expansion joint metal profile is fixed to the insulation board surface with a temporary fixing, prior to application of the reinforcing lath (see Figure 4).

Figure 4 Vertical movement joint

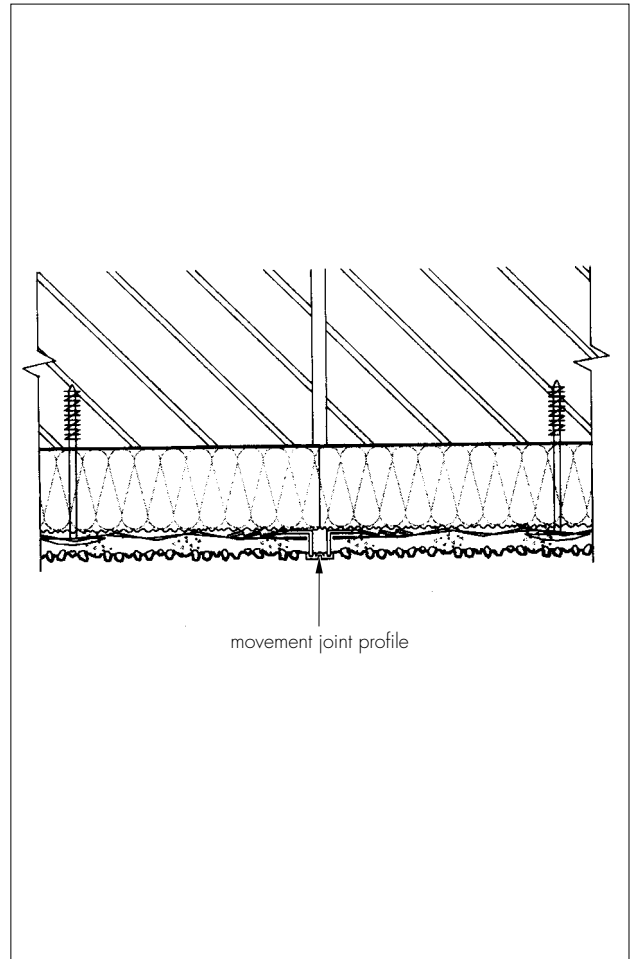

## Reinforcing

3.12 The reinforcing lath is chosen for the installation from one of the three alternative materials available according to the specifier's requirements.

3.13 The reinforcing lath is fixed against the insulation boards using mechanical fixings, at the specified minimum rate of five/board or seven fixings per m<sup>2</sup>. The fixings are positioned at a nominal 100 mm from the horizontal and vertical board edges and one in the centre of each board.

3.14 The lath joints should overlap by two diamonds (minimum), in either a horizontal or vertical direction and should be tied together at 150 mm intervals by inserting specified structural fixings, wiring together using stainless steel wire or snipping a strand of the lath and bending it over the lapping mesh.

# Electronic Copy

3.15 Large areas of render should not exceed 40 m<sup>2</sup> to 50 m<sup>2</sup>. The extent of a rendered area should take account of the shape of the work. Where necessary, render movement joints are formed by cutting the lath and fixing a weber expansion joint profile to the insulation board with a temporary fixing.

3.16 The undercoat is prepared and trowel applied upwards onto the insulation boards, so that it is forced behind the lath. It is applied in a thickness of 10 mm to 12 mm.

3.17 Care should be taken to achieve complete coverage of the lath and to butt the undercoat under details such as window-sills. The surface of the undercoat is trowelled smooth and scored or combed to provide a good, even, keyed surface for the topcoat finish.

## Beads

3.18 Expansion beads are fixed vertically as day joints, ideally over existing joints.

3.19 Stop beads are positioned vertically, eg at party-wall positions where the adjoining house does not require treatment.

3.20 Where required, angle beads are fixed to all building corners and to door and window heads and jambs.

## Render finishing

3.21 The undercoat must be left to cure for at least two to three days depending on weather conditions before application of the finish.

3.22 Prior to the render topcoat, a bead of clear silicone sealant is gun applied at window and door frames, overhanging eaves, gas and electric meter boxes, wall vents or where the render abuts any other building material or surface.

3.23 The finish coat can be either a traditional or polymer-modified cementitious type coat with a dry-dash, scraped or synthetic coat finish.

3.24 The topcoat is trowel applied onto the undercoat to a thickness of approximately 6 mm to 8 mm. While the render is still soft the dry-dash is applied to the topcoat with a dashing trowel. Narrow widths of weber.rend PTC/TTC around window and door openings and in reveals, may be smooth float finished and painted with weber.plast P. On completion, the surface should be checked to ensure an even coverage has been achieved. Where necessary, the aggregate should be lightly-tamped to ensure that a good bond is achieved.

3.25 Where a weber.plast TF and weber.plast DF or weber.sil TF finish is required, the primer is brush applied and allowed to dry.

The finishes should be mixed thoroughly before application over the topcoat. The chosen finish is applied with a steel trowel to a uniform thickness, depending on grain size and immediately worked with a thin plastic or wooden float to produce the desired texture (see section 1).

3.26 To prevent the finish from drying too rapidly, it should not be applied in direct sunlight. The finished render surface should be protected from rain and frost until the material is dry and hard, approximately 24 hours under favourable conditions, although in winter, this may take at least 48 hours. Continuous surfaces must be completed without a break.

3.27 At the tops of walls the system must be protected by an adequate overhang or by an adequately sealed, purpose-made flashing (see Figure 5).

Figure 5 Eaves detail — pitched roof

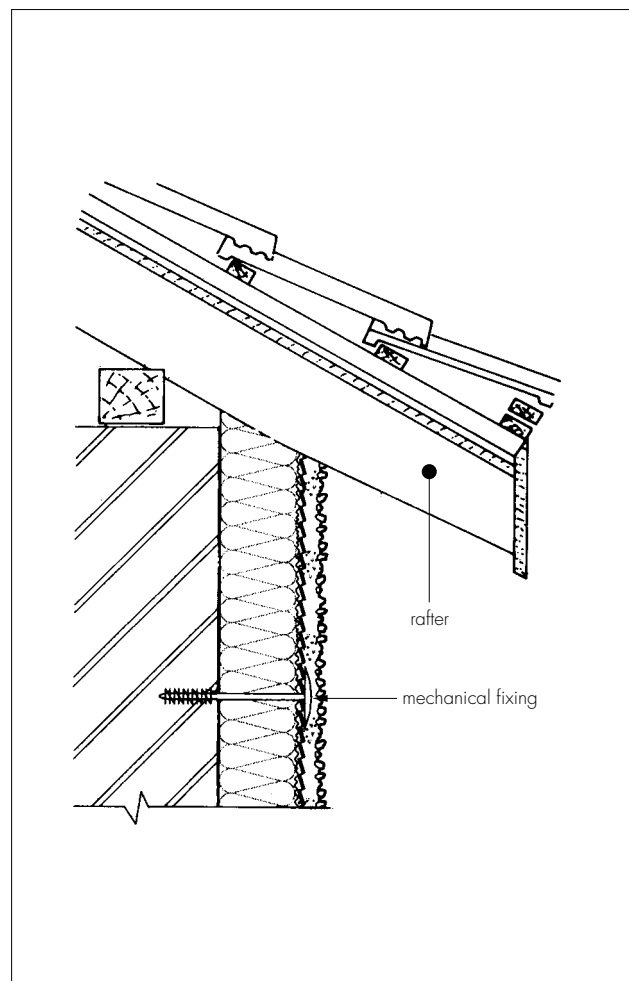

3.28 Care must be taken in the detailing of the system around openings and projections (see Figure 6).

3.29 On completion of the installation, external fittings, eg rainwater goods, are re-fixed through the system into the substrate.

Figure 6 Window details

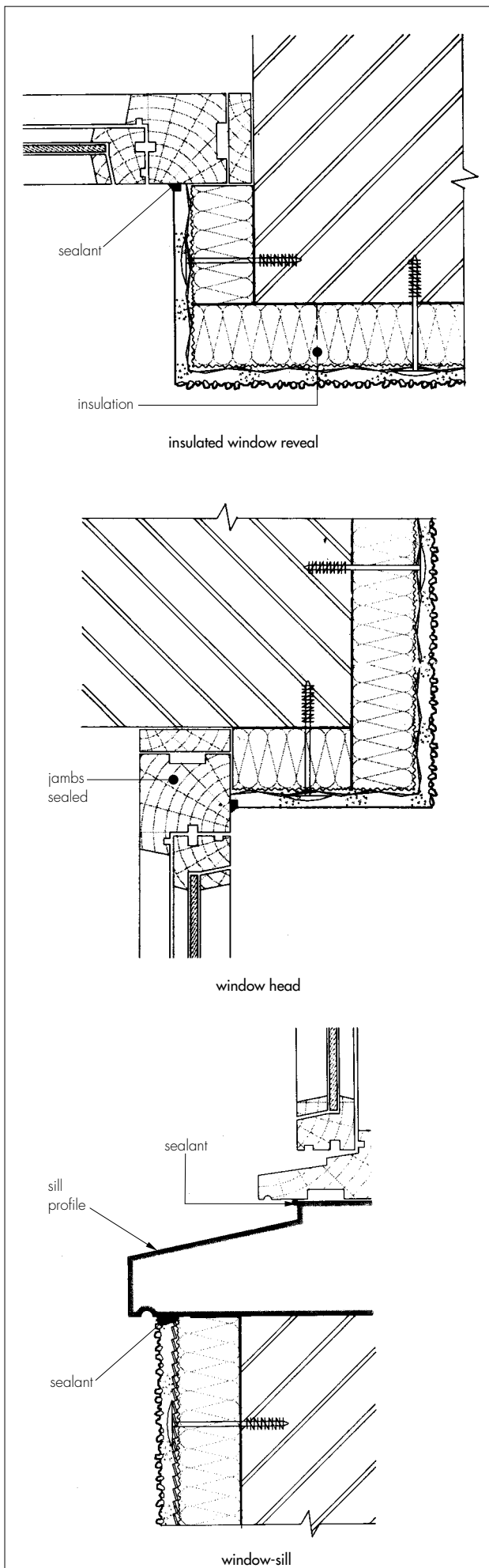

## Technical Investigations

The following is a summary of the technical investigations carried out on the weber.therm XL (EPS) External Wall Insulation System.

### 4 Tests

4.1 Tests were carried out in accordance with MOAT No 22 : 1988 to determine:

- component characterisation
- flexural and compressive strength of renders
- density of slab
- resistance to freeze/thaw
- heat/spray cycling
- impact resistance
- water absorption of render
- water permeability
- water vapour permeability.

4.2 An examination was made of data relating to:

- water vapour permeability
- water permeability
- fire propagation tests to BS 476-6 : 1989
- surface spread of flame tests to BS 476-7 : 1997
- pull-out strength of fixings
- durability of finish coatings.

### 5 Investigations

5.1 The manufacturing process, the methods adopted for quality control of manufactured and bought-in components, and details of the quality and composition of the materials used, were examined.

5.2 An assessment of the risk of interstitial condensation was undertaken.

5.3 The practicability of installation and the effectiveness of detailing techniques were examined.

5.4 A visit was made to a UK site in progress to assess the practicability of installation and the effectiveness of detailing techniques.

5.5 Visits were made to existing sites to assess the performance of the product in use.

5.6 A computer simulation of the risk of interstitial condensation was undertaken.

## Bibliography

BS 476-6 : 1989 *Fire tests on building materials and structures — Method of test for fire propagation for products*

BS 476-7 : 1997 *Fire tests on building materials and structures — Method of test to determine the classification of the surface spread of flame of products*

BS 5262 : 1991 *Code of practice for external renderings*

BS 8000-10 : 1995 *Workmanship on building sites — Code of practice for plastering and rendering*

BS EN 10051 : 1992 *Specification for continuously hot-rolled uncoated plate, sheet and strip of non-alloy and alloy steels — Tolerances on dimensions and shape*

BS EN 10088-1 : 1995 *Stainless steels — List of stainless steels*

BS EN 10259 : 1997 *Cold-rolled stainless steel and heat resisting steel wide strip and plate/sheet — Tolerances on dimensions and shape*

BS EN 10327 : 2004 *Continuously hot-dip coated strip and sheet of low carbon steels for cold forming — Technical delivery conditions*

BS EN 13163 : 2001 *Thermal insulation products for buildings — Factory made products of expanded polystyrene (EPS) — Specification*

MOAT No 22 : 1988 *UEAtc Directives for the Assessment of External Insulation Systems for Walls (Expanded Polystyrene Insulation Faced with a Thin Rendering)*



On behalf of the British Board of Agrément

Date of Second issue: 15th July 2005

A handwritten signature in black ink, appearing to read 'G. A. Cooper'.

Chief Executive

*\*Original Detail Sheet issued on 15th August 1991. This amended version includes a change of Certificate holder's name and new product and component names.*

# Electronic Copy

---

**British Board of Agrément**

P O Box No 195, Bucknalls Lane  
Garston, Watford, Herts WD25 9BA  
Fax: 01923 665301

©2005

e-mail: [mail@bba.star.co.uk](mailto:mail@bba.star.co.uk)  
website: [www.bbacerts.co.uk](http://www.bbacerts.co.uk)



For technical or additional information,  
contact the Certificate holder (see  
front page).  
For information about the Agrément  
Certificate, including validity and  
scope, tel: Hotline 01923 665400,  
or check the BBA website.